

EASYGATE SG

DISCREET. FAST. EFFECTIVE

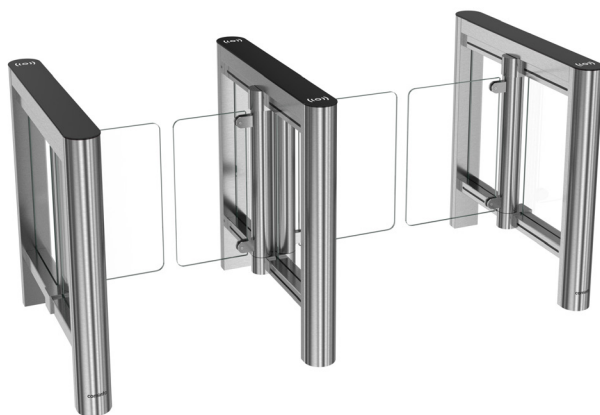

EASYGATE SG 1000



EASYGATE SG 1000

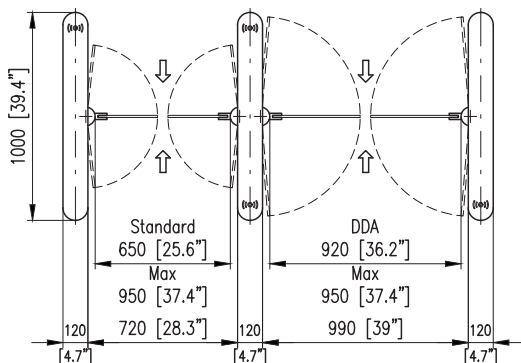
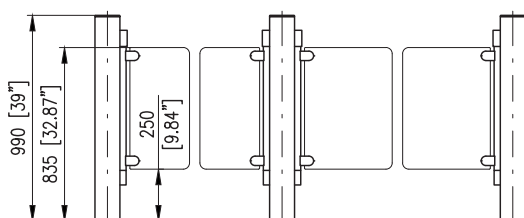

EASYGATE SG 1320

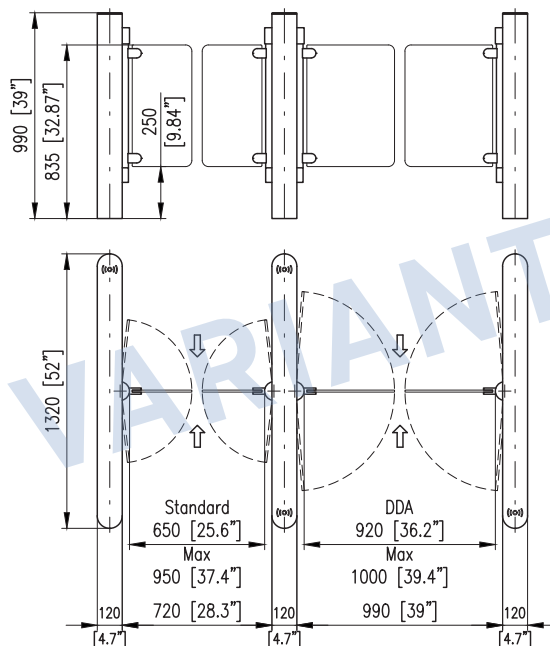

AT A GLANCE

- Available models: EasyGate SG 1000, EasyGate SG 1320 in your choice of square or round end
- Barrier opening time: from 0.7 seconds
- MTBF: of 3,000,000 operations
- 24 month warranty
- DDA Compliant

SPECIFICATIONS

DIMENSIONS

Standard:	1000mm(L) x 120mm(W) x 990mm(H)
Extended:	1320mm(L) x 120mm(W) x 990mm(H)
Barrier Height:	1000mm
Lane width:	500mm - 920mm (customisable)
Gap Between barriers:	50mm
MTBF:	3,000,000 operations
Warranty:	24 months
Sensors:	Up to 36 sensor pairs
Power Supply Input:	230 volts
Control Electronics:	12 V DC
Current:	Standby 0.4 A
Consumption:	Operational 6 A

Operating Temp:	-10°C to 50°C (with heater)
Motor:	12 V DC
Operation Mode:	Normally Closed
Control:	Card In / Card Out, Card In / No Exit, Card In / Free Exit, Locked, Free Passage
Pictograms:	Wait Mode (White Indicator) Access Granted (Green Indicator) Illegal Transaction (Red Indicator)
Barrier Opening Time (Standard lane):	0.7 seconds

MATERIALS

Top Cover:	8mm Smoked Safety Glass
Front Cover:	Stainless Steel
Side Panels:	Stainless Steel
Frame:	Steel

For Remote Turnstile Maintenance access to the sites network is required and the service is subject to a support agreement

entrancecontrol.com.au