

EASYGATE IM

SLEEK. STYLISH. CUSTOMISABLE.

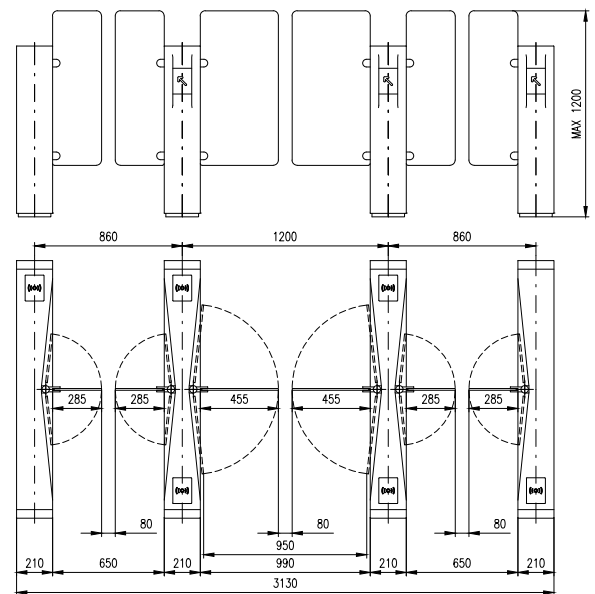
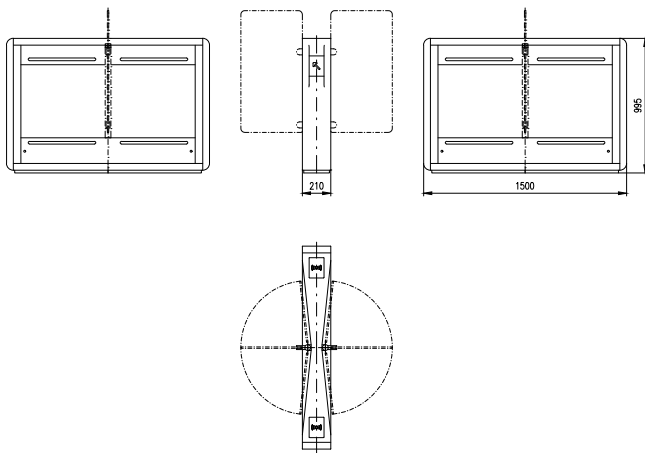

AT A GLANCE

- Available with square cabinet
- Barrier opening time from 0.5 seconds
- Customisable finishes
- DDA Compliant

SPECIFICATIONS

DIMENSIONS

Standard:	1500mm(L) x 210mm(W) x 995mm(H)
Wide:	1500mm(L) x 210mm(W) x 995mm(H)
Barrier Height:	1200mm (Standard), 1800mm (Max)
Lane width:	550mm - 1100mm (customisable)
Gap Between barriers:	80mm
Gap at Bottom of Glass:	300mm
MBTF:	5,000,000 operations
Sensors:	Up to 36 sensor pairs
Warranty:	36 months
Power Supply Input:	230 volts
Control Electronics:	12 V DC
Current:	Standby 0.4 A
Consumption:	Operational 6 A

Operating Temp:	10°C to 50°C (with heater)
Motor:	12 V DC
Operation Mode:	Normally Closed
Control:	Card In / Card Out Card In / No Exit Card In / Free Exit Locked Free Passage
Pictograms:	Wait Mode (White Indicator) Access Granted (Green Indicator) Illegal Transaction (Red Indicator)

Barrier Opening Time (Standard lane): 0.5 Seconds

MATERIALS

Top Cover:	Corian (other options)
Front Cover:	Corian
Side Panels:	Brushed Stainless Steel
Frame:	Steel

Specifications subject to change without prior notice.