

Centurion TriPod 400

The Centurion TriPod 400 is a stylish open design tripod turnstile which provides a reliable, effective and easy to use means of controlling access in and out of a facility. The 400 combines a proven motorised mechanism with a small footprint making it ideal for reception areas in high end leisure clubs and gyms as well as office building and other applications where design is a key criteria.



The Centurion 400 includes an option for an integrated bar code or proximity reader.

Reliable

The Centurion TriPod 400 comes with a sealed motorised drive which provides greater reliability, lower maintenance and faster, easier throughput than traditional mechanical units.

Safe

The Centurion TriPod 400 can integrate with the fire alarm system so it free wheels in an emergency. In addition there is an option for a drop arm which allows for a clear lane for emergency evacuation.

Flexible

The Centurion TriPod 400 can be installed alongside passgates such as the Centurion SwingGate to provide access for wheelchairs or deliveries.

Remote Control

The turnstile can be supplied with a desk mounted console or PC software to provide the reception team with easy control of the turnstiles functionality to facilitate visitor entry, simplify alarm monitoring and change operational modes.

In addition the turnstiles can be configured to allow remote diagnostics allowing engineers to dial in and undertake remote maintenance, servicing, configuration and trouble shooting saving on expensive site visits.

The CENTAMAN advantage...

- *Technically superior products*
- *Sydney based 24/7 support helpline*
- *Local offices for a faster response*
- *Flexible support packages*
- *Supply only to turnkey project delivery options*
- *14 Years experience in successfully delivering entrance control solutions*

Key Benefits

- European Design
- Motorised for Ease of Use
- 24 Month Warranty
- MTBF of 3,000,000 operations
- Sealed Drive Unit for 'Maintenance Free' operation
- Highly Cost Effective
- Advanced Technology
- Drop Arm Option for Emergency Egress
- Integrates with most Ticketing, Membership and Access Control Systems
- Remote access option for maintenance, trouble shooting & configuration
- Applications
Gyms, Industrial Sites, Sports Stadia, Leisure Clubs, Manufacturing Plants





CENTAMAN Entrance Control

Setting new standards in entrance control

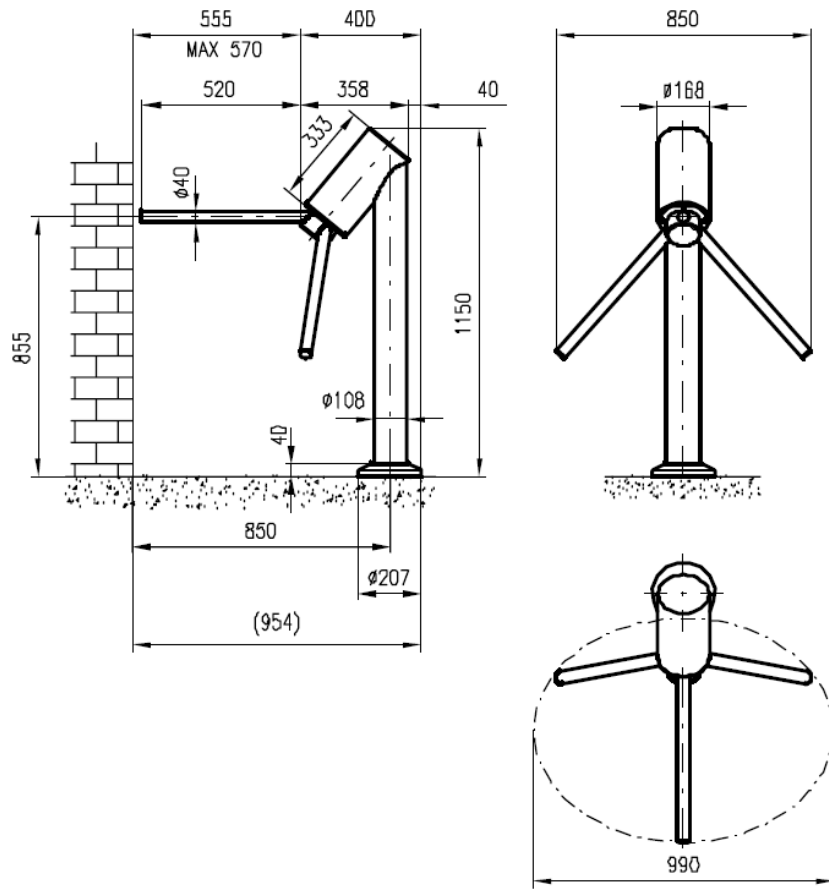

Specification

Dimensions

Standard: 850mm(L) x 400mm(W) x 1150mm(H)
Lane width 555mm

Power Supply Input : 230 volts
Control Electronics : 12 V DC
Current : Standby 0.1 A
Consumption : Operational 3 A
Operating Temp : -30°C to 50°C
Humidity : 80%
Motor : 12V DC

Operation Mode : Fail Secure
(Fail Safe Option)

Control : Card In / Card Out
Card In / No Exit
Option Card In / Free Exit
Locked
Free Wheel

Operating Parameters

- Operating temperature: -30°C to +50°C
- Humidity: maximum 80%
- MCBF: 3.000.000 cycles (Mean cycle before failure)

Options

Drop Arm
Fail Safe Motor (required for free exit)
LED Traffic Lights
Power Supply
Integrated Bar Code Reader

For Remote Turnstile Maintenance access to the sites network is required and the service is subject to a support agreement

NB: Specifications subject to change without prior notice

About CENTAMAN

CENTAMAN Systems Pty is the exclusive distributor for some of the world's most prestigious entrance control brands that are used to protect leading corporations, governments, leisure and education facilities as well as retailers around the globe. The products highlighted here are just some of the options available that make up the CENTAMAN portfolio of entrance control solutions.

With over 14 years experience successfully delivering entrance control solution and over 40 staff and operates 5 offices throughout Australia and New Zealand CENTAMAN is the ideal choice of partner for all your entrance control requirements. CENTAMAN offers supply only to full turnkey installation projects and has a variety of flexible support and maintenance options to ensure the ongoing reliable operation of your entrance control solution all backed by a Sydney based 24/7 support telephone support helpline.

Sydney Office

127 Alexander Street
Crows Nest
NSW 2065

Tel (02) 9906 7522

Melbourne Office

Unit 6
752 Blackburn Road,
Clayton
Vic 3168

Tel (03) 9530 6830

Brisbane Office

Level 13,
269 Wickham Street,
Fortitude Valley
QLD 4006

Tel (07) 3852 2535

Perth Office

Suite 8a,
7 Kintail Road,
Applecross
WA 6153

Tel (08) 9345 3599

New Zealand Office

Suite 4,
101 Station Rd,
Penrose
Auckland 1061

Tel (09) 579 4600

United States Office

31st Floor,
875 N Michigan Ave,
Chicago,
IL, 60611

Tel 1-800-804-9373