

Centurion FIT

Concept

The Centurion FIT tripod turnstile is an extremely cost effective means of controlling access in and out of a facility. The Centurion FIT combines a highly reliable mechanical mechanism with an extremely compact pedestal design available in a toughened paint finish making it ideal for applications such as reception areas in office buildings and leisure clubs as well as museum, transport and stadia applications.



The Centurion FIT

Reliable

With over 10,000 units installed around the world the Centurion FIT mechanism has a proven track record of reliability in a wide range of high throughput applications. At the heart of the turnstile this rugged mechanism only requires maintenance every 700,000 turns. This is achieved by a combination electro-magnets, as opposed to solenoids, alongside optical sensors to generate the rotation signals thereby minimising any potential mechanical wear and giving greater long term reliability.

Safe

The Centurion FIT can integrate with the fire alarm system so it free wheels in an emergency or power fail. .

Flexible

The FIT is designed to be used both indoor or outdoors under protective cover.

The Centurion FIT can be installed alongside passgates such as the Centurion PushGate and RotoGate to provide access for wheelchairs or deliveries.

The CENTAMAN advantage...

- *Technically superior products*
- *Sydney based 24/7 support helpline*
- *Local offices for a faster response*
- *Flexible support packages*
- *Supply only to turnkey project delivery options*
- *14 Years experience in successfully delivering entrance control solutions*

Key Benefits

- **Highly Cost Effective**
- **Reliable electromagnetic locking mechanism**
- **Mechanical tripod with compact footprint**
- **Rugged black epoxy powder coat paint finish**
- **Up to 700,000 turns in between maintenance visits**
- **Drop Arm Option for Emergency Egress**
- **Integrates with most Ticketing, Membership and Access Control Systems**
- **Applications**
Schools, Sports Stadia, Leisure Clubs, Manufacturing Plants, Offices, Attractions and Transport Facilities

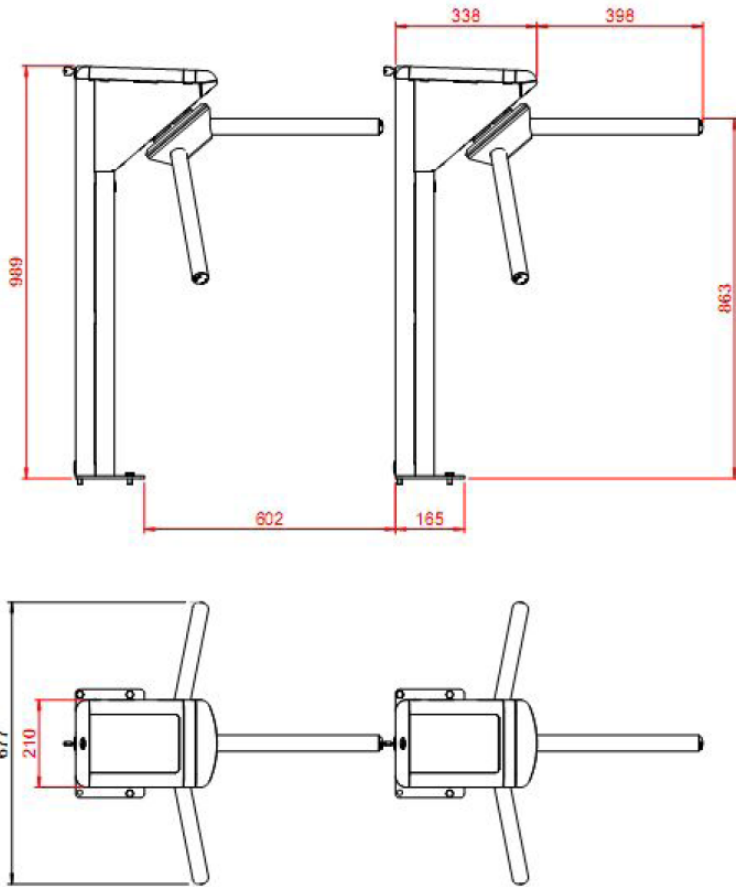

Specification

Dimensions

Standard: 210mm(L) x 750mm(W) x 969mm(H)
Lane width 450–500mm

Electrical

Power Supply : Mains
Electromagnet supply voltage : 12 V and 2 A
Sensor supply voltage : 5 V and 0.5 A

Operation

Mode : Fail Secure (Fail Safe Option)
Control : Card In / Card Out
Card In / No Exit
Option Card In / Free Exit
Locked
Free Wheel

Packaging

Height: 103 cm
Width: 27 cm
Depth: 55 cm
Gross Weight
37 kg (+ 2 kg of packaging)

Options

Drop Arm
Traffic Lights
Stainless Steel Finish
Visitor Card Return
Power Supply
Card Reader Mounting Options
Counter

NB: Specifications subject to change without prior notice

About CENTAMAN

CENTAMAN Systems Pty is the exclusive distributor for some of the world's most prestigious entrance control brands that are used to protect leading corporations, governments, leisure and education facilities as well as retailers around the globe. The products highlighted here are just some of the options available that make up the CENTAMAN portfolio of entrance control solutions.

With over 14 years experience successfully delivering entrance control solution and over 40 staff and operates 5 offices throughout Australia and New Zealand CENTAMAN is the ideal choice of partner for all your entrance control requirements. CENTAMAN offers supply only to full turnkey installation projects and has a variety of flexible support and maintenance options to ensure the ongoing reliable operation of your entrance control solution all backed by a Sydney based 24/7 support telephone support helpline.

Sydney Office

127 Alexander Street
Crows Nest
NSW 2065

Tel (02) 9906 7522

Melbourne Office

Unit 6
752 Blackburn Road,
Clayton
Vic 3168

Tel (03) 9530 6830

Brisbane Office

Level 13,
269 Wickham Street,
Fortitude Valley
QLD 4006

Tel (07) 3852 2535

Perth Office

Suite 8a,
7 Kintail Road,
Applecross
WA 6153

Tel (08) 9345 3599

New Zealand Office

Suite 4,
101 Station Rd,
Penrose
Auckland 1061

Tel (09) 579 4600

United States Office

31st Floor,
875 N Michigan Ave,
Chicago,
IL, 60611

Tel 1-800-804-9373